

Image shown may not reflect actual engine configuration

PACKAGE SPECIFICATIONS

I-4, 4-Stroke-Cycle Diesel

Emissions	Non-regulated
Peak Torque at Speed	
(with fan)	477 N•m (352 lb-ft) @ 1800 rpm
Bore	105 mm (4.13 in)
Stroke	127 mm (5 in)
Displacement	4.4 L (268.5 in ³)
Aspiration	Turbocharged-Aftercooled
Governor and Protection	Woodward
Weight, Net Dry (approx)	1118.5 kg (2465lbs)
Capacity for Liquids	
Lube System (refill)	9 L (9.5 U.S. qts)
Cooling System	24.6 L (26.0 U.S. qts)
Oil Change Interval	500 hours
Rotation (from flywheel end)	Counterclockwise
Flywheel and Flywheel Housing	SAE No. 3
Flywheel Teeth	126

FEATURES

Improving Workforce Efficiency

- Standard factory certifications improve worksite safety
 - ATEX Directive (2014/34/EU) Group IIA
 - Category 3G (Zone 2) Temperature Class T3.
- Certified flameproof intake system to prevent any internal explosions from propagating to external atmosphere
- ATEX-designed and tested exhaust system, compliant to EN 1834-1

Making Your Investment Work Harder

- Maintains high power over broad range of operating speeds, improving performance
- Steady torque rise provides superior load acceptance
- Optimized ambient and altitude capabilities for operating flexibility

Driving Down Total Cost of Ownership

- Improved serviceability versus the competition
- 350 hour* exhaust flame arrestor interval option

** Dependent on duty cycle and fuel quality*

HAZPAK SOLUTION

- Matched exhaust and inlet systems
- Take the risk out of specification and procurement of individual parts
- All skin temperatures and exhaust gas < 200°C (T3)
- Certified to maintain T3 skin temperatures for up to 45°C ambient applications

Class-leading safety

- ATEX 2014/34/EU
- Machinery Safety Directive 2006/42/EC
- IECEx

STANDARD PACKAGE EQUIPMENT

Air Inlet System

ATEX-designed and tested inlet system, compliant to EN 1834-1; stainless steel flame arrestor; integrated air shutdown valve, activates on overspeed and emergency stop; available in hydraulic or pneumatic configurations; air cleaner, single element canister type with service indicator and rain cap

Cooling System

Closed cooling system with air blast radiator and charge air cooling, marine radiator with full solder-dipped core, radiator cooled packages sized for 45°C ambient air temp, gear-driven centrifugal jacket water pump, de-aeration expansion tank, exhaust gas heat exchanger, additional heat load from exhaust heat exchanger included in cooling circuit

Exhaust System

ATEX-designed and tested exhaust system, compliant to EN 1834-1; comprised of exhaust gas heat exchanger; stainless steel flame arrestor; stainless steel spark arrestor; water-cooled exhaust manifold, water-cooled turbocharger

Flywheel and Flywheel Housing

SAE 3 flywheel housing, 126 tooth flywheel

Fuel System

Mechanical fuel injection, primary fuel filter/ water separator with 1/4" BSPP connectors (LH), secondary fuel filter (LH), fuel priming pump manual, fuel shutoff valve

General

Package ambient capability is -20°C to 45°C; designed for Gas Group IIA; all systems meet temperature class T3 (200°C limit); includes a declaration of conformity for the entire package scope; radiator package, engine, and exhaust system fitted to sub-frame; air filter, fuel/water separator, remote oil filter installed and mounted; earth bonding per standard EN 60079-14

Lube System

Oil filter (LH), locking dipstick (LH), locking oil filler, flame trap breather

OPTIONAL EQUIPMENT

Air Compressor

Single cylinder, 225 CC with head unloader

Charging System

12V, 45A alternator with 75AH battery pack

24V 16A alternator with 75AH battery pack

24V 25A alternator with 75AH battery pack

Control System

Local panel at side of engine, includes: coolant temperature gauge, lube oil pressure gauge, exhaust gas temperature gauge, exhaust gas backpressure gauge, engine speed gauge, stop switch

Exhaust System

18 dBA spark arrestor/muffler, ATEX-approved

Shutdown System

Pneumatic and hydraulic solutions

Starting System

Pneumatic, electric, and hydraulic starters

PERFORMANCE DATA

Turbocharged-Aftercooled — 2200 rpm

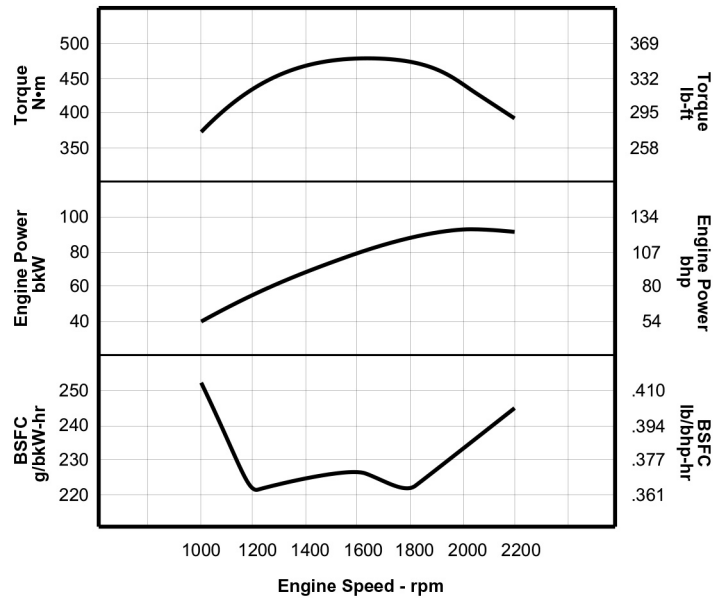

General Performance Data Including Fan						
Engine Speed rpm	Engine Power		Engine Torque		BSFC	
	bkW	bhp	N•m	lb-ft	g/bkW-hr	lb/bhp-hr
2200	91	122	395	291	244.9	.403
2100	92	123	418	308	238.2	.392
2000	92	123	439	324	232.7	.383
1900	91	122	457	337	227.5	.374
1800	90	121	477	352	221.2	.364
1700	84	113	472	348	224.7	.369
1600	78	105	466	344	226.2	.372
1500	74	99	471	347	223.0	.367
1400	68	91	464	342	224.1	.368
1300	62	83	455	336	223.9	.368
1200	56	75	446	329	221.3	.364
1100	47	63	408	301	236.7	.389
1000	39	52	372	274	252.6	.415

DIMENSIONS

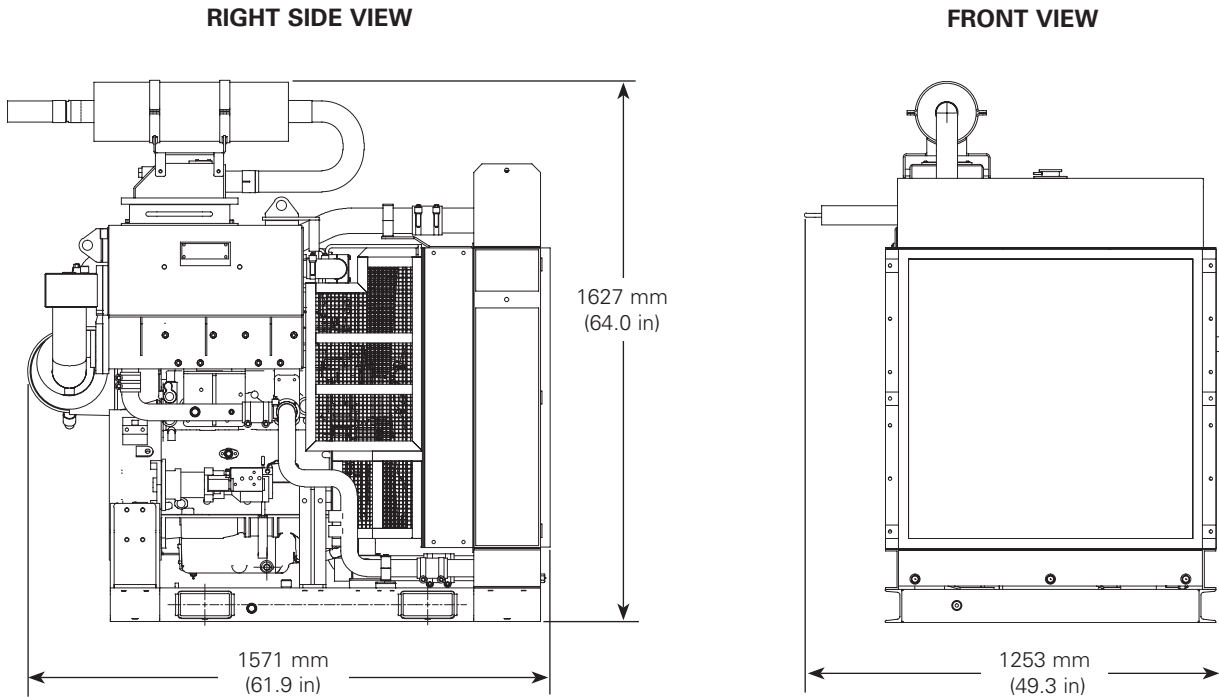

DIMENSIONS*		
Length	mm (in)	1571 (61.9)
Width	mm (in)	1253 (49.3)
Height	mm (in)	1627 (64.0)
Shipping Weight	kg (lb)	970 (2138)

*Typical dimension shown. Height will increase if silenced spark arrestor is chosen.